

C40-A multisignal panel meter

Multisignal digital panel meter, configurable to work with process signals (mA and Vdc), thermocouples (K, J, E, N, L, R, S, B, T, C), resistive temperature probes (Pt100, Pt500, Pt1000, Ni100, Ni100 and NTC), resistances, AC and DC voltages (up to 400V) and AC and DC currents (up to 5 A). AC measures in True RMS. Standard 96x48 mm (1/8 DIN) size, for panel mount. Scalable reading with 4 digits (9999 to -1999) and configurable decimal point. 'Fast access' function to alarm setpoints, configurable special functions accessible with rear contact, 'Eco' mode for low consumption, 5 configurable brightness levels. Universal AC and DC power options. Optional outputs for relay, analog output and serial communications RS-485 ASCII. Recommended for OEM applications.



Technical specifications

Digits	4
Reading	9999 / -1999
Decimal point	configurable
Led color	red
Digit height	14 mm
Accepted signal ranges	<i>see tables at page 3 for more information</i>
• AC voltages and AC currents	400 Vac, 200 Vac, 20 Vac, 2 Vac 200 mVac, 60 mVac, 5 Aac, 20 mAac
• DC voltages and DC currents	±400 Vdc, ±200 Vdc, ±20 Vdc, ±2 Vdc ±200 mVdc, ±60 mVdc, ±5 Adc, ±20 mAdc
• thermocouples	K, J, E, N, L, R, S, B, T and C
• resistive 'Pt' probes	Pt100, Pt500, Pt1000
• resistive 'Ni' probes	Ni100, Ni120
• resistive NTC probes	<i>see table at page 3</i>
• process	4/20 mA, 0/10 Vdc
• resistances	ranges 0/10 K and 0/100 K
Accuracy	<i>see tables at page 3</i>
Thermal drift offset+span	150 ppm/°C
Readings	3 readings/ second
Refresh	3 readings/ second
Response time	<300 mSec. (0% to 99% of signal)
Power 'H'	85 to 265 Vac/dc (isolated 2500Veff @60seconds)
Power 'L'	11 to 60Vdc and 24/48Vac (isolated 1500Veff @60seconds)
Output and control options	1 or 2 relays 1 analog output 4/20 mA isolated 1 serial output RS-485 ASCII isolated
Protection	IP50 standard (optional IP54, IP65)

Dimensions (mm)

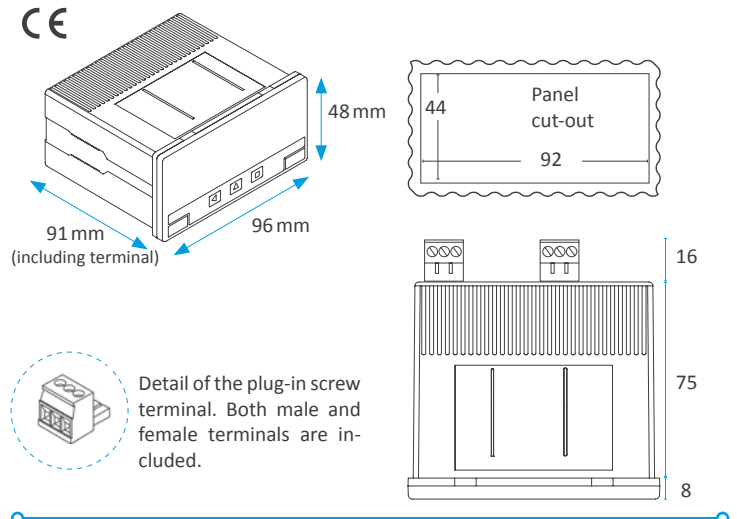

Consumption (normal mode)	<1.0 W (meter only) <2.5 W (meter with options)
Consumption ('Eco' mode)	<0.3 W (meter only) <1.5 W (meter with options)
Connections	plug-in screw terminals
Weight	<150 grams
Mounting	panel mount
Front size	96 x 48 mm (1/8 DIN)
Panel cut-out	92 x 44 mm
Deep	91 mm (including terminals)
Temperature of operation	0 to 50 °C

How to order

Series	Model	Power	Option 1	Option 2	Others	Customization
C40	A	H				
		-H (85-265 Vac/dc) -L (11/60 Vdc, 24 Vac, 48 Vac)	-A1 (1 relay) -M1 (analog output) -S1 (RS-485 ASCII) -(empty)	-A2 (1 relé) -(empty)	-EK (external control) -NBT (no front keypad) -54 (front IP54) -65 (front IP65) -(empty)	-XXXX (customized execution) -(empty)

Additional documentation

User's manual C40-A	www.fema.es/docs/3987en_C40-A_manual.pdf
Datasheet C40-A	www.fema.es/docs/3988en_C40-A_datasheet.pdf
Quick installation guide C40-A	www.fema.es/docs/3989en_C40-A_installation.pdf
CE declaration of conformity	www.fema.es/docs/3990en_C40-A_conformity.pdf
Warranty	www.fema.es/docs/3991en_C40-A_warranty.pdf

Functions included

- 'Fast access' menu press the 'UP' ('▲') front key to access and modify the alarm setpoints, and / or the maximum and minimum memory. Configurable menu.
- 'External control' function. connect a contact to the rear terminal, and configure a function to be associated with that contact : activate the 'second scaling', control the decimal point 0, 1, 2 or 3, perform a 'hold' on the reading or activate the maximum or minimum memory.
- 'Eco' mode. automatic turn off of the display leds, to reduce the consumption of the instrument when the operator is not using it.
- Alarms 1 or 2 alarms, independent, configurable as maximum or minimum, with setpoint and hysteresis.
- Reading offset this function allows to configure a fixed number of counts to be added to the reading.
- 'Second scaling' function. define two scalings for the same signal and control which one is active with the 'External control' option.
- Display filters. recursive filter for noisy signals and configurable steps for minimum predefined changes on the reading.
- Output and control options. optional 1 or 2 relay outputs, 1 analog 4/20 mA isolated output, 1 serial RS-485 ASCII isolated output.
- Brightness configurable 5 levels of brightness intensity.
- Password blocks the configuration menu.

Connections and rear view

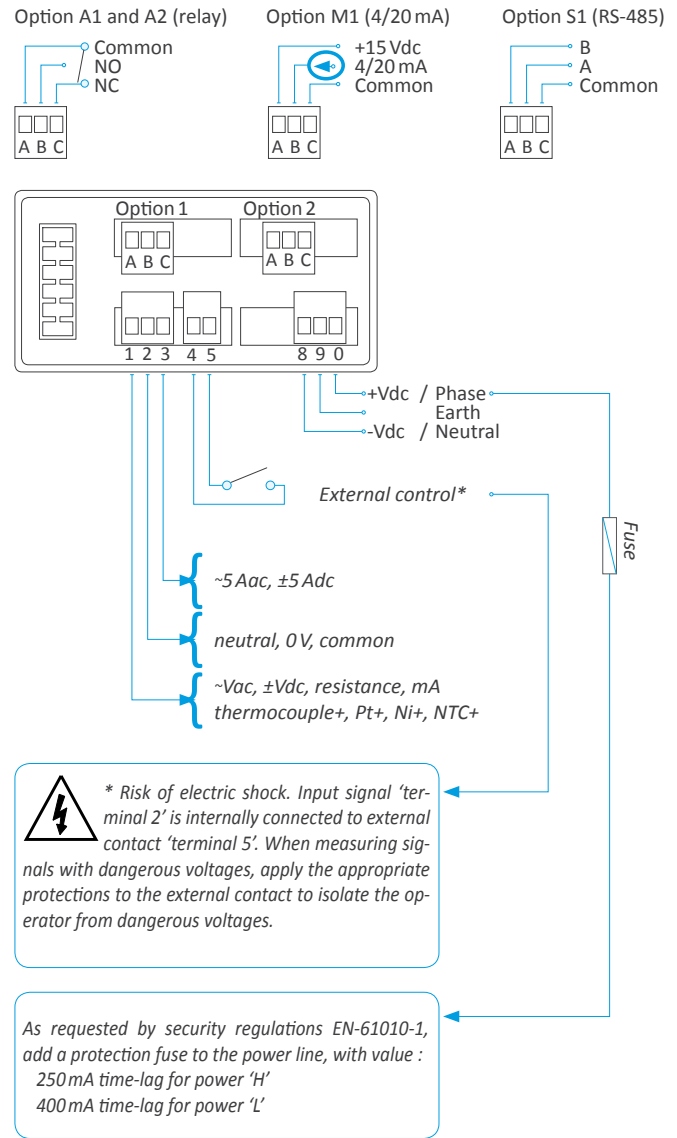

Internal structure - Jumpers for input range selection

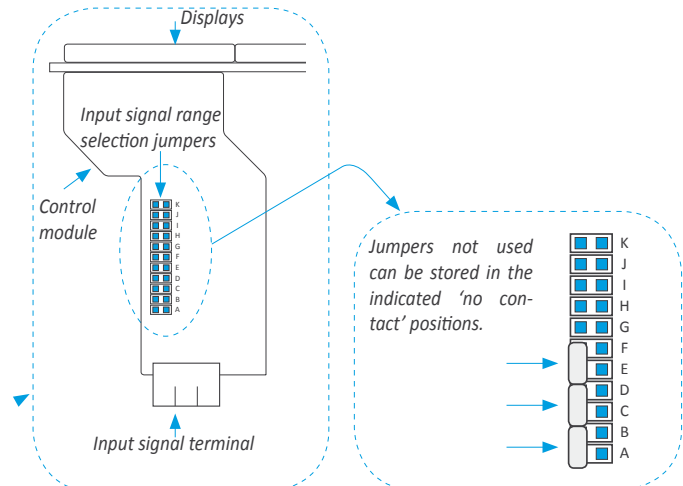
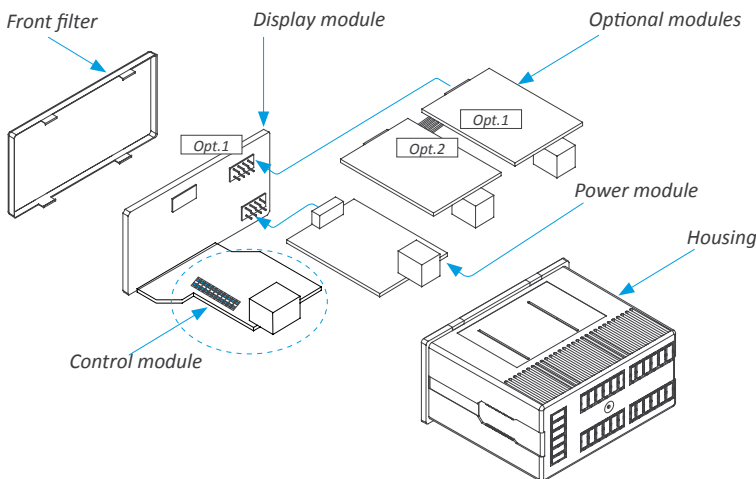

Input signal ranges - Technical specifications

Vac ranges (Veff.)	Scale by default	Scalable	Jumper	Accuracy (% FS)	Max. signal (Vp)	Z _{in}	Max. over-signal
400 Vac	400	from 9999 to -1999	I	<0.25 %	600 Vp	12 M	1000 Vp
200 Vac	200.0		A I		325 Vp	4.4 M	400 Vp
20 Vac	20.00		B I		32.5 Vp	477 K	200 Vp
2 Vac	2.000		C I		3.25 Vp	45 K	100 Vp
200 mVac	200.0		D I	325 mVp	4.4 K	20 Vp	
60 mVac	60.0		E I	<0.25 %	132 mVp	2.2 K	1 Vp

Vdc ranges	Scale by default	Scalable	Jumper	Accuracy (% FS)	Max. signal (Vdc)	Z _{in}	Max. over-signal
±400 Vdc	400	from 9999 to -1999	---	<0.20 %	600 Vdc	12 M	1000 Vdc
±200 Vdc	200.0		A		325 Vdc	4.4 M	400 Vdc
±20 Vdc	20.00		B		32.5 Vdc	477 K	200 Vdc
±2 Vdc	2.000		C		3.25 Vdc	45 K	100 Vdc
±200 mVdc	200.0		D	325 mVdc	4.4 K	20 Vdc	
±60 mVdc	60.0		E	<0.25 %	132 mVdc	2.2 K	1 Vdc

Aac ranges (Aeff.)	Scale by default	Scalable	Jumper	Accuracy (% FS)	Max. signal (Ap)	Z _{in}	Max. over-signal
5 Aac	5.000	from 9999 to -1999	I	<0.25 %	8.5 Ap	20mOhm	16 Ap
20 mAac	20.00		F I	<0.15 %	32 mAap	4.7 R	125 mAap

Adc ranges	Scale by default	Scalable	Jumper	Accuracy (% FS)	Max. signal (Adc)	Z _{in}	Max. over-signal
±5 Adc	±5.000	from 9999 to -1999	---	<0.25 %	8.5 Adc	20mOhm	16 Adc
±20 mAdc	±20.00		F	<0.15 %	32 mAdc	4.7 R	125 mAdc

Process ranges	Scale by default	Scalable	Jumper	Accuracy (% FS)	Max. signal	Z _{in}	Max. over-signal
4/20 mA	0/100.0	from 9999 to -1999	F	<0.15 %	32 mA	4.7mOhm	125 mA
0/10 Vdc	0/100.0		B	<0.20 %	32.5 Vdc	477 K	200 Vdc

NTC probes 'R ₂₅ '	Jumper	Range of measure	Total error (% of reading)	Beta (configurable)
..., 1K, 1.5K, 2K, 2.2K, 3.3K, 4.7K, 5K, 6.8K, 10K, 12K, 15K, 22K, ...	G K	de 100 R a 100 K	<1.5% of reading	from 2000 to 5000

Note - to obtain the measurable range of temperature in degrees, check at the table provided by the NTC manufacturer, the temperature associated with 100 R and the temperature associated with 100 K

Thermocouples	Jumper	Range in °C (in °F)	Total error (cold junction included)
Thermocouple K	E	-200/1350 °C (-328/2462 °F)	<3°
Thermocouple J	E	-200/1200 °C (-328/2192 °F)	
Thermocouple E	E	-190/1000 °C (-310/1832 °F)	
Thermocouple N	E	-200/1300 °C (-328/2372 °F)	
Thermocouple L	E	-200/900 °C (-328/1652 °F)	
Thermocouple C	E	0/2300 °C (-32/4172 °F)	
Thermocouple R	E J	-50/1768 °C (-58/3214 °F)	
Thermocouple S	E J	-50/1768 °C (-58/3214 °F)	
Thermocouple B	E J	70/1820 °C (158/3308 °F)	
Thermocouple T	E J	-200/400 °C (-328/752 °F)	

Pt and Ni probes	Jumper	Range in °C (in °F)	Total error	Current at sensor
Pt100	G H	-200/750 °C (-328/1382 °F)	<1°	<900 uA
Pt500	G	-150/630 °C (-238/1166 °F)		<900 uA
Pt1000	G	-190/630 °C (-310/1166 °F)		<90 uA
Ni100	G H	-60/180 °C (-76/356 °F)		<900 uA
Ni120	G H	-80/245 °C (-112/473 °F)		<900 uA

Resistance ranges	Jumper	Total error (% of reading)
0 to 10 K	G H K	<1.5% of reading
0 to 100 K	G K	

Options and accessories

Relay outputs

Module A1 and A2
Function. 1 relay output
3 contacts (NC, NO, Common)
up to 250 Vac @ 8 Ampere

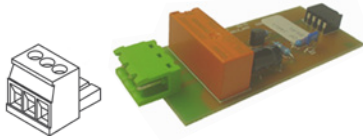

Analog output

Module M1
Function. 1 analog output isolated
4/20 mA
isolated 1000 Vdc

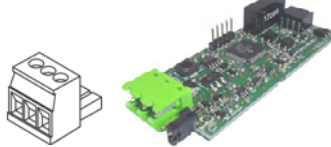

Output RS-485 ASCII

Module S1
Function. 1 communication RS-485
isolated 1000 Vdc

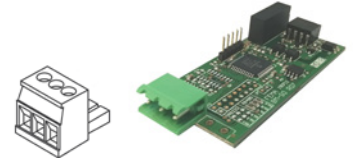

Benchtop housing

Reference THM



DIN rail mount adapter

Reference DRA-M



Wall mount housing

Reference WME



Option without keypad

Reference NBT



Protection IP54

Reference 54



Protection IP65

Reference 65



Option 'External control'

Reference EK



Option 'customized'

Customization of standard instruments

- improved technical performances
- custom configurations
- special functions
- ...

